

# 2023 Horticulture Display Guidelines for Plant Societies, Guilds & Organizations

updated 1/3/23



## Display Information:

- All displays should be educational artistically designed.
- The display will be maintained by the society or organization at a high standard of quality for the duration of the fair. **A set-up premium of \$350.00 will be paid to each society.**
- All displays will be inside the Florida Center building.
- The fair will not provide the mulch for the displays.
- Societies, Guilds and organizations are welcome to be at their display any time during the fair. This is a great way to share information and create public awareness.
- The display location will be assigned after all applications are confirmed. The size of the display will be 10' x 10'.

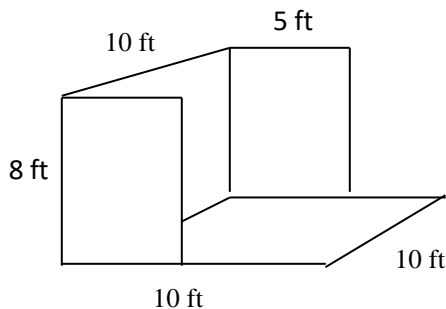

**Attention**  
All water must be retained within your booth.  
You may use pot trays.

## Schedule

Confirm that your organization will be participating in the plant display	<b>December 31, 2022 (FRI)</b>
Display setup	<b>February 3 – 7, 2023 (FRI – TUES) 9:00 a.m. – 9:00 p.m.</b>
People’s Choice	<b>February 9 – 20, 2023</b>
All displays must be removed completely (including mulch)	<b>February 21 - 22, 2023 (TUES &amp; WED) 9:00 a.m. – 9:00 p.m.</b>

## Awards

People’s Choice Award	<b>\$150</b>
-----------------------	--------------

For any additional information or questions, please call Brenda Gregory at (813) 734-2810, or email: [brenda.gregory@floridastatefair.com](mailto:brenda.gregory@floridastatefair.com).

# 2023 Horticulture Display Application

**A completed application should be received by Saturday, December 31<sup>st</sup>, 2022.**

**Mail completed form back to:**

Florida State Fair – Horticulture Display  
Attn: Brenda Gregory  
P.O. Box 11766  
Tampa, FL 33680

**Scan & Email to:**

brenda.gregory@floridastatefair.com  
**Question? Phone:** 813-734-2810

---

Name of Society, Guild or Organization

---

Contact Person

---

Who does the check get written out to?

---

Address

---

City

State

Zip code

---

Cell Phone

---

Email

---

Organization Website or Facebook Page

How many Fair tickets will you need for your organization to care for your display during the Fair? \_\_\_\_\_

Will you need a **LOAD IN/LOAD OUT Pass** for the Florida Center building during Fair?  YES  NO **How many?** \_\_\_\_\_

**NOTE:** Each vehicle will need only one Pass with the dates that they will be allowed access (we usually provide access the entire Fair dates).

How many years have you participated in the Florida State Fair? \_\_\_\_\_  We are new to the Fair.

Will you need electricity for your display?  YES  NO

List any special needs \_\_\_\_\_

**What days can you staff your display?**  FEB 9  FEB 10  FEB 11  FEB 12  FEB 13  FEB 14

FEB 15  FEB 16  FEB 17  FEB 18  FEB 19  FEB 20

*I understand that the 2022 Creative Living Competitions & Exhibits are held in conjunction with the 2022 Florida State Fair and agree that the Florida State Fair is not liable or responsible for any delay, change of dates or cancellation of the 2022 Florida State Fair due the following unforeseeable circumstances: (a) acts of God; (b) flood, fire, earthquake; or (c) other potential disaster(s) or catastrophe(s), such as epidemics, pandemics, or explosion.*

---

Signature of Contestant

Date

