

2024 Horticulture Display Guidelines for Plant Societies, Guilds & Organizations

updated 9/23/23



Display Information:

- All displays should be educational artistically designed.
- The display will be maintained by the society or organization at a high standard of quality for the duration of the fair. **A set-up premium of \$350.00 will be paid to each society.**
- NEW** • All societies or organizations will be required to do educational presentations for fair attendees each weekend. Plan for 2 – 30-minute presentations each weekend. We will need to know what you will be doing in mid-January so we can let marketing know.
- All displays will be inside the Florida Center building.
- The fair will not provide the mulch for the displays.
- All water must be retained within your booth. You may use pot trays.
- Societies, Guilds, and organizations are welcome to be at their display any time during the fair. This is a great way to share information and create public awareness.
- NEW** • The display location will be assigned after all applications are confirmed. The size of the display will be 8' wide x 10' deep. Please note the change in booth size and style. See

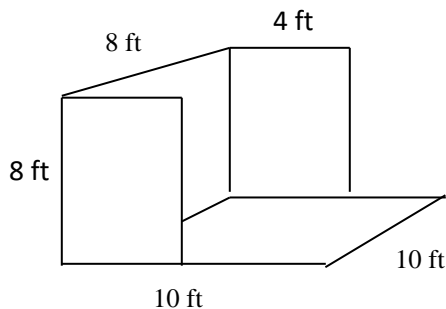

**See New
Display Specifications
on Page 2.**

Schedule

Confirm that your organization will be participating in the plant display	December 31, 2022 (SUN)
Display setup	February 2 – 6, 2024 (FRI – TUES) 9:00 a.m. – 9:00 p.m.
People’s Choice	February 8 – 19, 2024
All displays must be removed completely (including mulch)	February 20 - 21, 2024 (TUES & WED) 9:00 a.m. – 9:00 p.m.

Awards

People’s Choice Award	\$150
-----------------------	--------------

For any additional information or questions, please call Brenda Gregory at (813) 734-2810, or email: brenda.gregory@floridastatefair.com.

Display Specifications

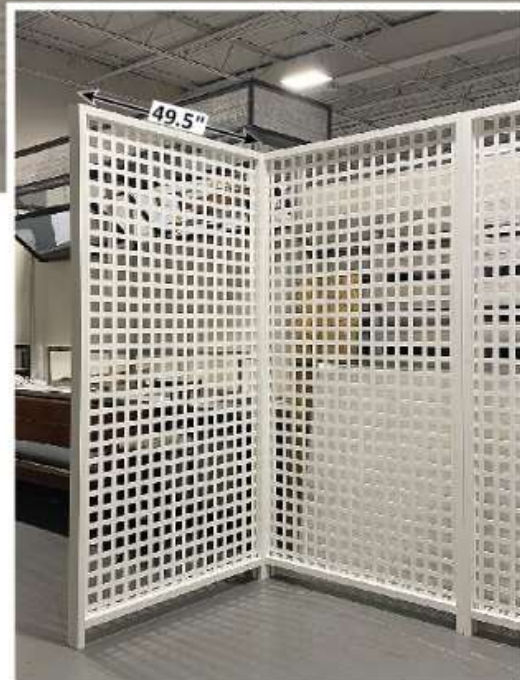
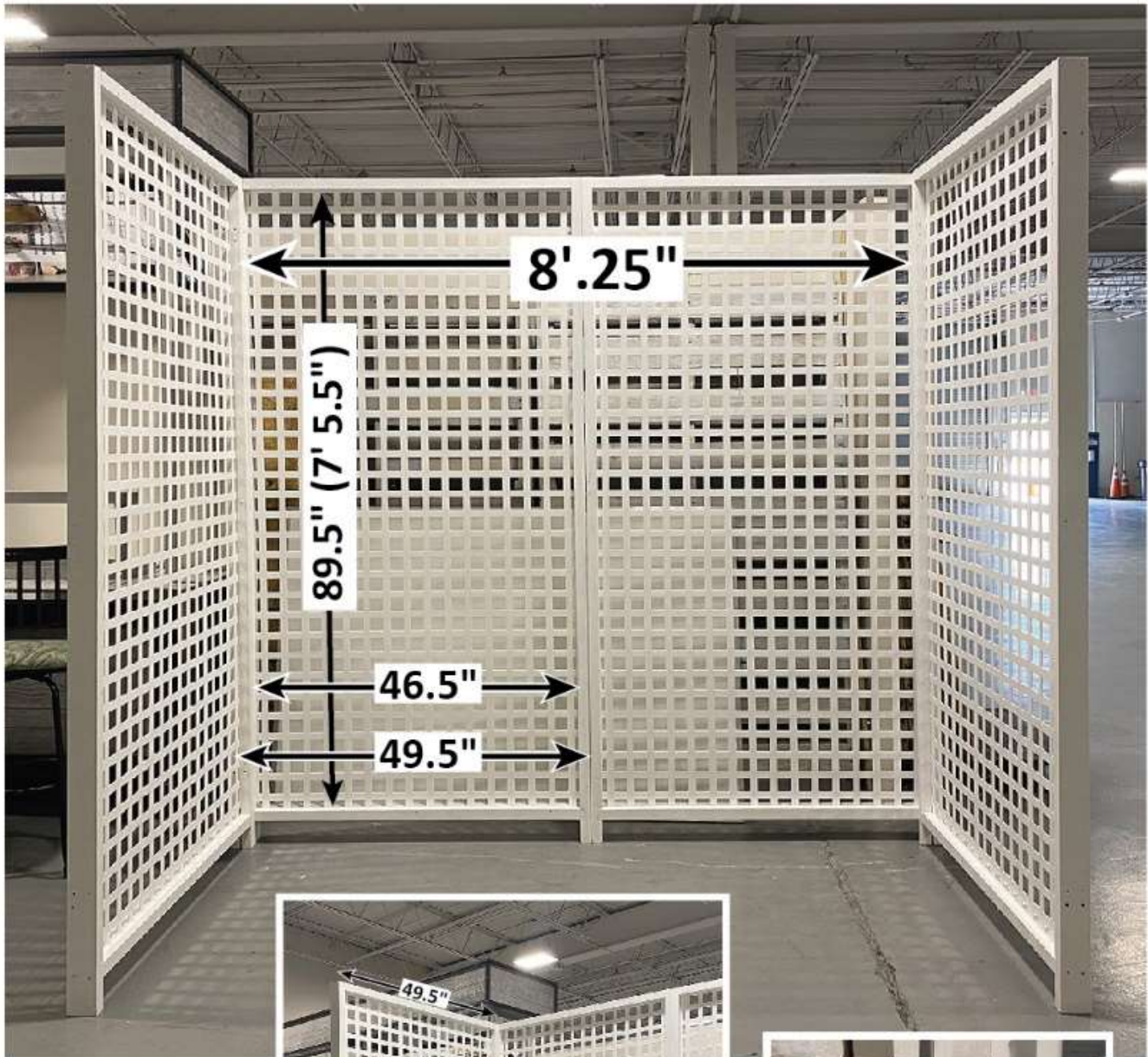

Corner



Close up of corner

2024 Horticulture Display Application

A completed application should be received by Sunday, December 31st, 2023.

Mail completed form back to:

Florida State Fair – Horticulture Display
Attn: Brenda Gregory
P.O. Box 11766
Tampa, FL 33680

Scan & Email to:

brenda.gregory@floridastatefair.com
Question? Phone: 813-734-2810

Name of Society, Guild or Organization

Contact Person

Who does the check get written out to?

Address

City

State

Zip code

Cell Phone

Email

Organization Website or Facebook Page

How many Fair tickets will you need for your organization to care for your display during the Fair? _____

Will you need a **LOAD IN/LOAD OUT Pass** for the Florida Center building during Fair? YES NO **How many?** _____

NOTE: Each vehicle will need only one Pass with the dates that they will be allowed access (we usually provide access the entire Fair dates).

How many years have you participated in the Florida State Fair? _____ We are new to the Fair.

Will you need electricity for your display? YES NO

List any special needs _____

What days can you staff your display? FEB 8 FEB 9 FEB 10 FEB 11 FEB 12 FEB 13

FEB 14 FEB 15 FEB 16 FEB 17 FEB 18 FEB 19

I understand that the 2024 Creative Living Competitions & Exhibits are held in conjunction with the 2024 Florida State Fair and agree that the Florida State Fair is not liable or responsible for any delay, change of dates or cancellation of the 2024 Florida State Fair due the following unforeseeable circumstances: (a) acts of God; (b) flood, fire, earthquake; or (c) other potential disaster(s) or catastrophe(s), such as epidemics, pandemics, or explosion.

Signature of Contestant

Date